



HDMI Receiver Port Protection and Interface Device

CM2021-02TR

Features

- HDMI 1.3 compliant
- 0.05pF matching capacitance between the TMDS intra-pair
- Level shifting/isolation circuitry
- Provides ESD protection to IEC61000-4-2 Level 4:
 - ±8kV contact discharge
 - ±15kV air discharge
- Matched 0.5mm trace spacing (TSSOP)
- Simplified layout for HDMI connectors
- Backdrive protection
- RoHS-compliant, lead-free packaging

Applications

- PC
- Consumer electronics
- Displays and digital television

Product Description

The CM2021-02TR HDMI Receiver Port Protection and Interface Device is specifically designed for next generation HDMI Host interface protection.

An integrated package provides all ESD, level shift and backdrive protection for an HDMI port in a single 38-Pin TSSOP package.

The CM2021-02TR part is specifically designed to complement the CM2020 protection part in HDMI transmitters (DVD, STB/OPVR, etc.).

Electrical Schematic

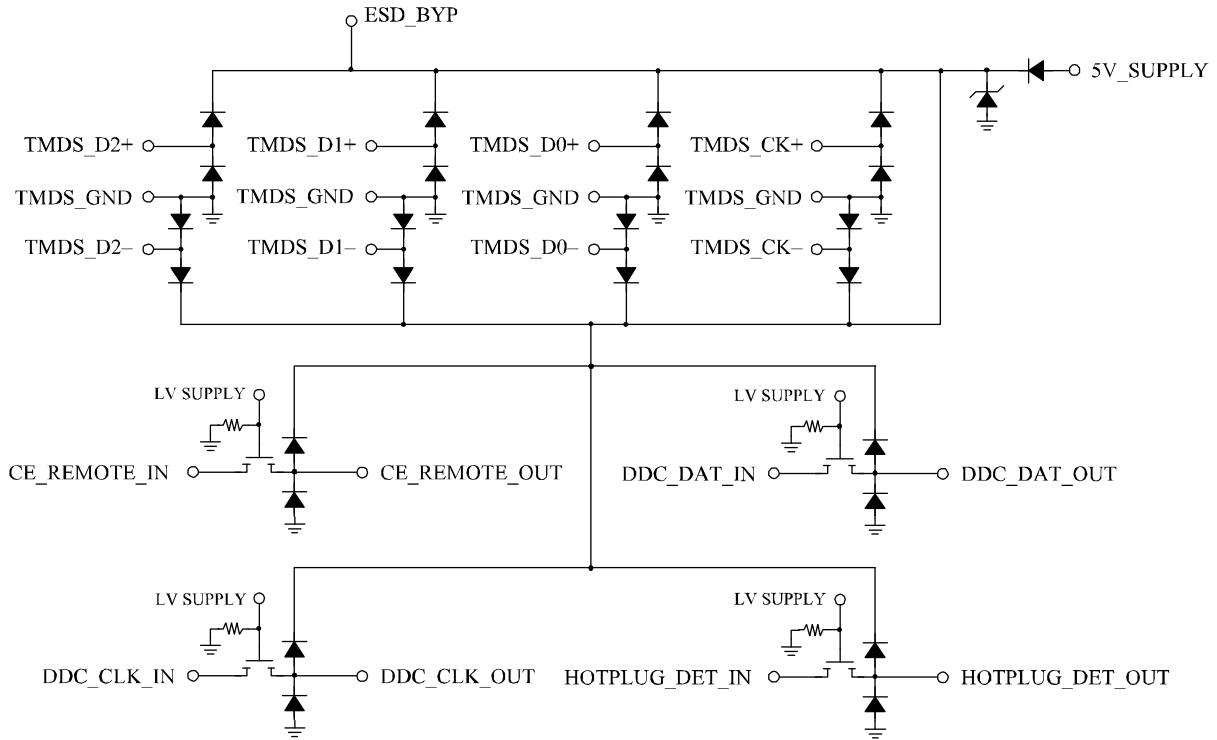

PACKAGE / PINOUT DIAGRAM

TOP VIEW

5V_SUPPLY	1	38	NC
LV_SUPPLY	2	37	ESD_BY
GND	3	36	GND
TMDS_D2+	4	35	TMDS_D2+
TMDS_GND	5	34	TMDS_GND
TMDS_D2-	6	33	TMDS_D2-
TMDS_D1+	7	32	TMDS_D1+
TMDS_GND	8	31	TMDS_GND
TMDS_D1-	9	30	TMDS_D1-
TMDS_D0+	10	29	TMDS_D0+
TMDS_GND	11	28	TMDS_GND
TMDS_D0-	12	27	TMDS_D0-
TMDS_CK+	13	26	TMDS_CK+
TMDS_GND	14	25	TMDS_GND
TMDS_CK-	15	24	TMDS_CK-
CE_REMOTE_IN	16	23	CE_REMOTE_OUT
DDC_CLK_IN	17	22	DDC_CLK_OUT
DDC_DAT_IN	18	21	DDC_DAT_OUT
HOTPLUG_DET_IN	19	20	HOTPLUG_DET_OUT

38-PIN TSSOP PACKAGE

Note: This drawing is not to scale.

PIN DESCRIPTIONS

PINS	NAME	ESD Level	DESCRIPTION
4, 35	TMDS_D2+	8kV ²	TMDS 0.9pF ESD protection. ¹
6, 33	TMDS_D2-	8kV ²	TMDS 0.9pF ESD protection. ¹
7, 32	TMDS_D1+	8kV ²	TMDS 0.9pF ESD protection. ¹
9, 30	TMDS_D1-	8kV ²	TMDS 0.9pF ESD protection. ¹
10, 29	TMDS_D0+	8kV ²	TMDS 0.9pF ESD protection. ¹
12, 27	TMDS_D0-	8kV ²	TMDS 0.9pF ESD protection. ¹
13, 26	TMDS_CK+	8kV ²	TMDS 0.9pF ESD protection. ¹
15, 24	TMDS_CK-	8kV ²	TMDS 0.9pF ESD protection. ¹
16	CE_REMOTE_IN	2kV ³	LV_SUPPLY referenced logic level into ASIC.
23	CE_REMOTE_OUT	8kV ²	5V_SUPPLY referenced logic level out plus 3.5pF ESD to connector.
17	DDC_CLK_IN	2kV ³	LV_SUPPLY referenced logic level into ASIC.
22	DDC_CLK_OUT	8kV ²	5V_SUPPLY referenced logic level out plus 3.5pF ESD to connector.
18	DDC_DAT_IN	2kV ³	LV_SUPPLY referenced logic level into ASIC.
21	DDC_DAT_OUT	8kV ²	5V_SUPPLY referenced logic level out plus 3.5pF ESD to connector.
19	HOTPLUG_DET_IN	2kV ³	LV_SUPPLY referenced logic level into ASIC.
20	HOTPLUG_DET_OUT	8kV ²	5V_SUPPLY referenced logic level out plus 3.5pF ESD to connector.
2	LV_SUPPLY	2kV ³	Bias for CE / DDC / HOTPLUG level shifters.
1	5V_SUPPLY	2kV ³	Current source for 5V_OUT.
37	ESD_BYP	2kV ³	This pin may be connected to a 0.1 F ceramic capacitor, but it is not necessary.
5, 34, 8, 31, 11, 28, 14, 25	TMDS_GND	N/A	TMDS ESD and Parasitic GND return. ⁴
3, 36	GND	N/A	Supply GND reference.
38	NC	N/A	No connect.

Note 1: These 2 pins need to be connected together in-line on the PCB.

Note 2: Standard IEC 61000-4-2, C_{DISCHARGE}=150pF, R_{DISCHARGE}=330Ω, 5V_SUPPLY and LV_SUPPLY within recommended operating conditions, GND=0V, each bypassed with a 0.1μF ceramic capacitor connected to GND.

Note 3: Human Body Model per MIL-STD-883, Method 3015, C_{DISCHARGE}=100pF, R_{DISCHARGE}=1.5kΩ, 5V_SUPPLY and LV_SUPPLY within recommended operating conditions, GND=0V, and each bypassed with a 0.1μF ceramic capacitor connected to GND.

Note 4: These pins should be routed directly to the associated GND pins on the HDMI connector with single point ground vias at the connector

Backdrive Protection

Two scenarios below describe what can happen when a powered device is connected to an unpowered device via an HDMI interface, substantiating the need for backdrive protection for this type of interface.

In a classic scenario, a DVD player is connected to a TV via an HDMI interface. If the DVD player is switched off and the TV is left on, there is a possibility of reverse current flow back into the main power supply rail of the DVD player. Typically, the DVD's power supply has some form of bulk supply capacitance associated with it. Because all CMOS logic exhibits a very high impedance on the power rail node when "off," if there is very little parasitic shunt resistance and as little as a few milliamps of "backdrive" current flowing back into the power rail, it is possible over time to charge that bulk supply capacitance to some intermediate level. If this level rises above the power-on-reset (POR) voltage level of some of the integrated circuits in the DVD player, these devices may not reset properly when the DVD player is turned back on.

In a more serious scenario, if any SOC devices are incorporated in the design which have built-in level shifter and DRC diodes for ESD protection, there is even a higher risk for damage. In this case, if there is a pullup resistor (such as with DDC) on the other end of the cable, that resistance will pull the SOC chips "output" up to a high level. This will forward bias the upper ESD diode in the DRC and charge the bulk capacitance in a similar fashion like above. If the current flow is high enough, even as little as a few milliamps, it could destroy one of the SOC chip's internal DRC diodes, as they are not designed for passing DC.

To avoid either of these situations, the CM2021-02TR is designed to block backdrive current, guaranteeing no more than 5 μ A on any I/O pin when the I/O pin voltage is greater than the CM2021-02TR supply voltage.

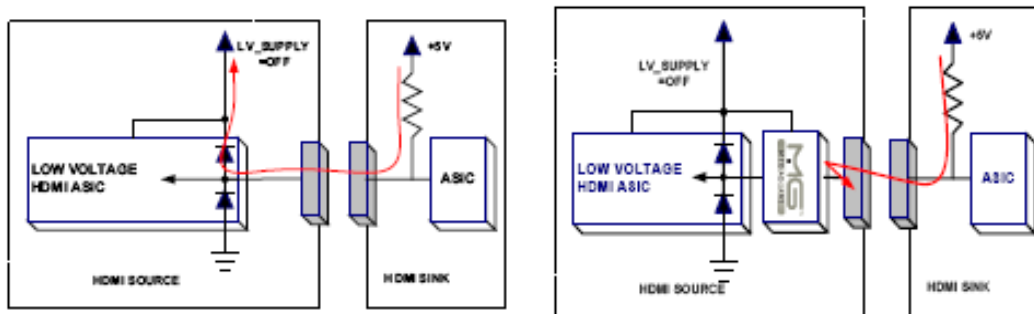

Figure 1. Backdrive Protection Diagram

CM2021-02TR

Ordering Information

PART NUMBERING INFORMATION			
Pins	Package	Lead-free Finish	
		Ordering Part Number ¹	Part Marking
38	TSSOP-38	CM2021-02TR	CM2021-02TR

Note 1: Parts are shipped in Tape and Reel form unless otherwise specified.

Specifications

ABSOLUTE MAXIMUM RATINGS		
PARAMETER	RATING	UNITS
V_{CCSV}, V_{CCLV}	6.0	V
DC Voltage at any Channel Input	6.0	V
Storage Temperature Range	-65 to +150	°C

STANDARD (RECOMMENDED) OPERATING CONDITIONS					
SYMBOL	PARAMETER	MIN	TYP	MAX	UNITS
5V_SUPPLY	Operating Supply Voltage	GND	5	5.5	V
LV_SUPPLY	Bias Supply Voltage	1	3.3	5.5	V
	Operating Temperature Range	-40		85	°C

ELECTRICAL OPERATING CHARACTERISTICS (SEE NOTE 1)

SYMBOL	PARAMETER	CONDITIONS	MIN	TYP	MAX	UNITS
I_{CCSV}	Operating Supply Current	5V_SUPPLY = 5.0V		110	130	μ A
I_{CCLV}	Bias Supply Current	LV_SUPPLY = 3.3V		1	5	μ A
I_{OFF}	OFF state leakage current, level shifting NFET	LV_SUPPLY = 0V		0.1	5	μ A
$I_{BACKDRIVE}$	Current conducted from output pins to V_SUPPLY rails when powered down	5V_SUPPLY V _{CH,OUT} ; Signal pins: TMDS_[2:0] +/-, TMDS_CK +/-, CE_REMOTE_OUT, DDC_DAT_OUT, DDC_CLK_OUT, HOTPLUG_DET_OUT Only		0.1	5	μ A
$I_{BACKDRIVE, CEC}$	Current through CE-REMOTE_OUT when powered down	CE-REMOTE_IN = CE_SUPPLY < CE_REMOTE_OUT		0.1	1	μ A
V_{ON}	VOLTAGE drop across level shifting NFET when ON	LV_SUPPLY = 2.5V, V _S = GND, I _{DS} = 3mA	75	95	140	mV
V_F	Diode Forward Voltage Top Diode Bottom Diode	I _F = 8mA, T _A = 25°C; Note 2	0.6 0.6	0.85 0.85	0.95 0.95	V V
V_{ESD}	ESD Withstand Voltage (IEC)	Pins 4, 7,10,13, 20, 21, 22, 23, 24, 27, 30, 33; Notes 2 and 3	8			kV
V_{CL}	Channel Clamp Voltage Positive Transients Negative Transients	T _A = 25°C, I _{PP} = 1A, t _p = 8/20 μ s; Notes 2 and 4		11.0 -2.0		V V
R_{DYN}	Dynamic Resistance Positive Transients Negative Transients	T _A = 25°C, I _{PP} = 1A, t _p = 8/20 μ s; Notes 2 and 4		1.2 0.9		Ω Ω
I_{LEAK}	TMDS Channel Leakage Current	T _A = 25°C; Note 2		0.01	1	μ A
$C_{IN, TMDS}$	TMDS Channel Input Capacitance	5V_SUPPLY = 5.0V, Measured at 1MHz, V _{BIAS} =2.5V; Note 2		0.9	1.2	pF
$\Delta C_{IN, TMDS}$	TMDS Channel Input Capacitance Matching	5V_SUPPLY = 5.0V, Measured at 1MHz, V _{BIAS} =2.5V; Notes 2 and 5		0.05		pF

CM2021-02TR

SYMBOL	PARAMETER	CONDITIONS	MIN	TYP	MAX	UNITS
C_{IN_DDC}	Level Shifting Input Capacitance, Capacitance to GND	5V_SUPPLY = 5V, Measured at 100KHz, $V_{BIAS}=2.5V$; Note 2		3.5	4	pF
C_{IN_CEC}	Level Shifting Input Capacitance, Capacitance to GND	5V_SUPPLY = 5V, Measured at 100KHz, $V_{BIAS}=2.5V$; Note 2		3.5	4	pF
C_{IN_HP}	Level Shifting Input Capacitance, Capacitance to GND	5V_SUPPLY = 5V, Measured at 100KHz, $V_{BIAS}=2.5V$; Note 2		3.5	4	pF

Note 1: Operating characteristics are over standard operating conditions unless otherwise specified.

Note 2: This parameter is guaranteed by design and verified by device characterization.

Note 3: Standard IEC 61000-4-2, $C_{DISCHARGE}=150pF$, $R_{DISCHARGE}=330\Omega$, 5V_SUPPLY and LV_SUPPLY within recommended operating conditions, GND=0V, each bypassed with a 0.1 μ F ceramic capacitor connected to GND.

Note 4: These measurements performed with no external capacitor on ESD_BYP.

Note 5: Intra-pair matching, each TMDS pair (i.e. D+, D-)

Performance Information

Typical Filter Performance ($T_A=25^{\circ}\text{C}$, DC Bias=0V, 50 Ohm Environment)

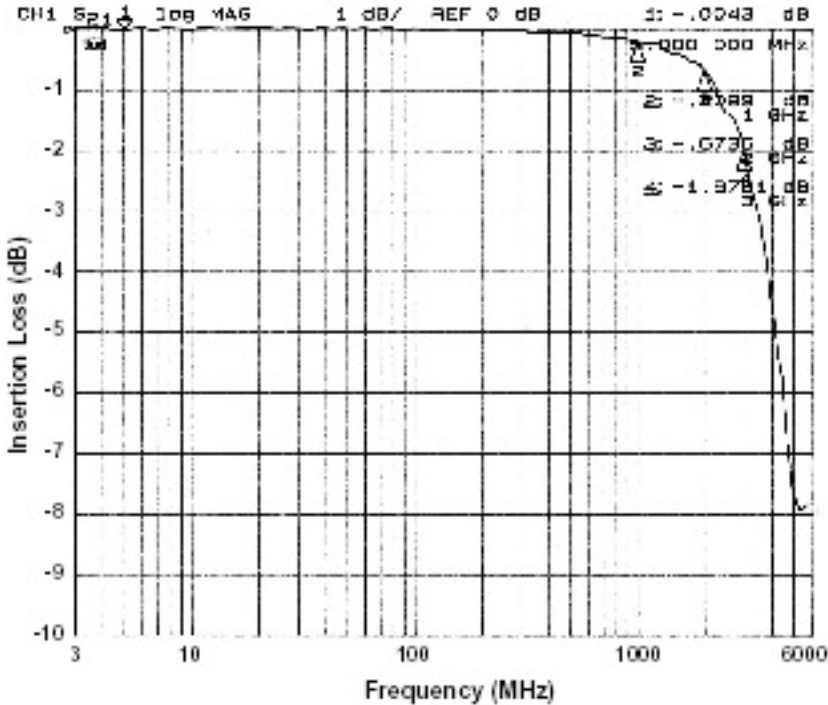
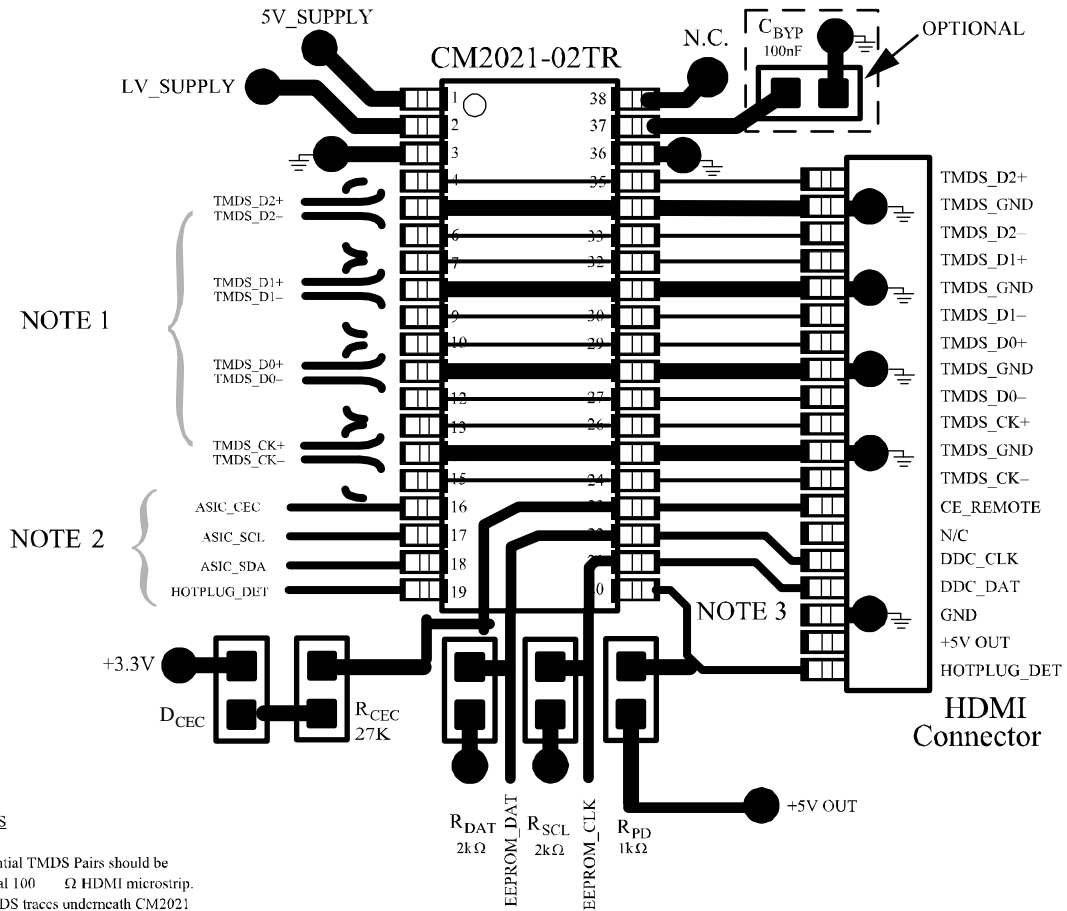

Figure 2. Insertion Loss vs. Frequency (TMS_D1- to GND)

CM2021-02TR

Application Information



LAYOUT NOTES

NOTE 1) Differential TMDS Pairs should be designed as normal 100 Ω HDMI microstrip. Single Ended TMDS traces underneath CM2021 and between CM2021 and Connector should be tuned to match chip/connector parasitics. (See MediaGuard™ Application Notes.)

NOTE 2) Level Shifter signals should be biased with a weak pullup to the desired local LV_SUPPLY. If the local ASIC includes sufficient pullups to register a logic high when the CM2021 NEFET is "off", then external pullups are not needed.

NOTE 3) Place CM2021 as close to connector as possible, and as with any controlled impedance line avoid ANY silkscreening over TMDS lines.

Figure 3. Typical Application for CM2021-02TR

Application Information

Design Considerations

1. DUT On vs. DUT Off

Many HDMI CTS tests require a power off condition on the System Under Test. Many Dual Rail Clamp (DRC) ESD diode configurations will be forward biased when their VDD rail is lower than the I/O pin bias, thereby exhibiting extremely high apparent capacitance measurements, for example. The *MediaGuard* backdrive isolation circuitry limits this current to less than 10mA, and will help ensure HDMI compliance.

2. EEPROM Configurations

The EDID EEPROM may be connected to either the ASIC LV domain or Connector 5V domain of the CM2021. See the *MediaGuard* EEPROM Application Note for further circuit connection and layout examples.

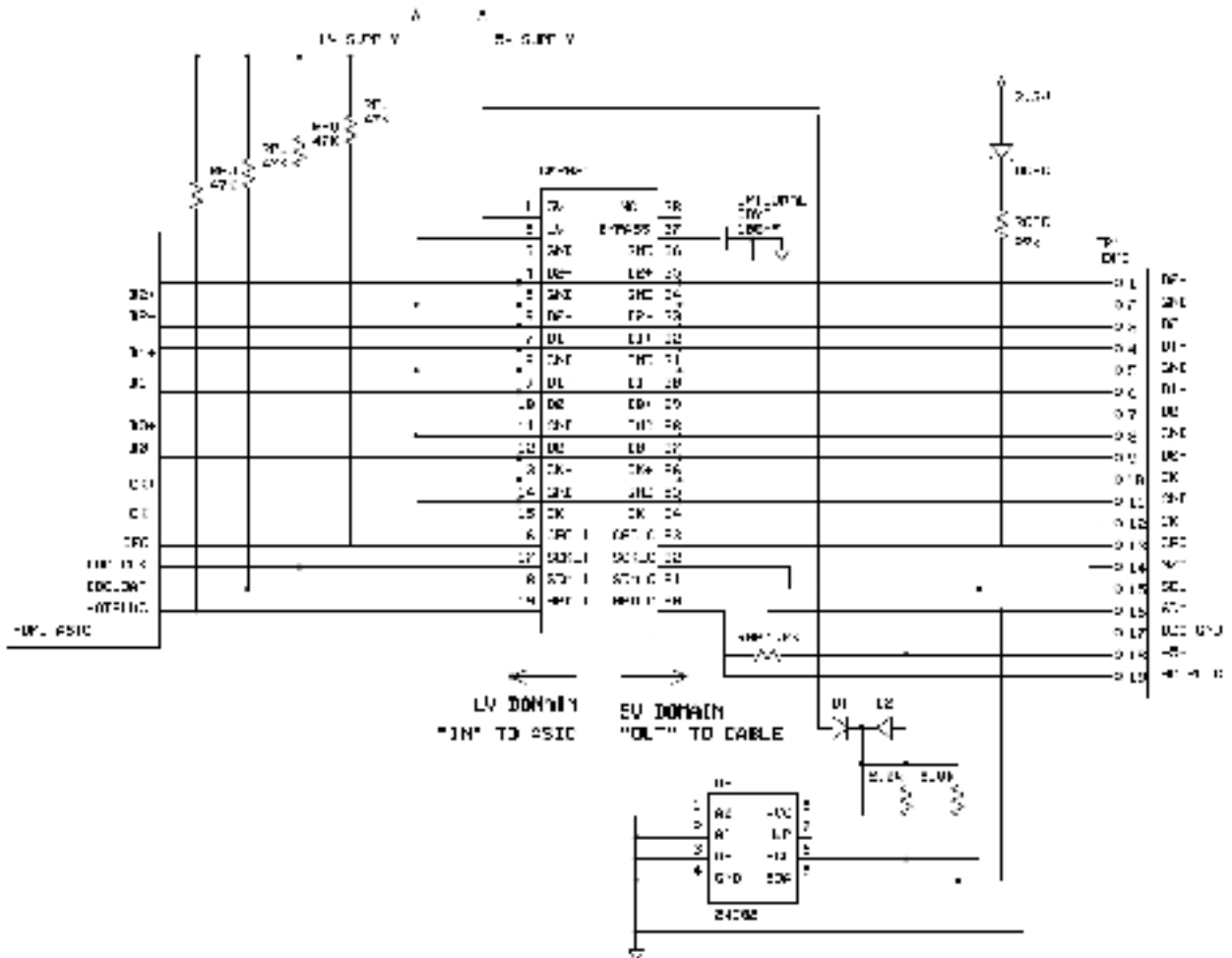

Figure 4. Design Example

CM2021-02TR

Mechanical Details

TSSOP-38 Mechanical Specifications

CM2021-02TR devices are supplied in 38-pin TSSOP packages. Dimensions are presented below. For complete information on the TSSOP-38, see the California Micro Devices TSSOP Package Information document.

PACKAGE DIMENSIONS				
Package	TSSOP			
JEDEC No.	MO-153 (Variation BD-1)			
Pins	38			
Dimensions	Millimeters		Inches	
	Min	Max	Min	Max
A	—	1.20	—	0.047
A1	0.05	0.15	0.002	0.006
b	0.17	0.27	0.007	0.011
c	0.09	0.20	0.004	0.008
D	9.60	9.80	0.378	0.386
E	6.40 BSC		0.252 BSC	
E1	4.30	4.50	0.169	0.177
e	0.50 BSC		0.020 BSC	
L	0.45	0.75	0.018	0.030
# per tape and reel	2500 pieces			
Controlling dimension: millimeters				

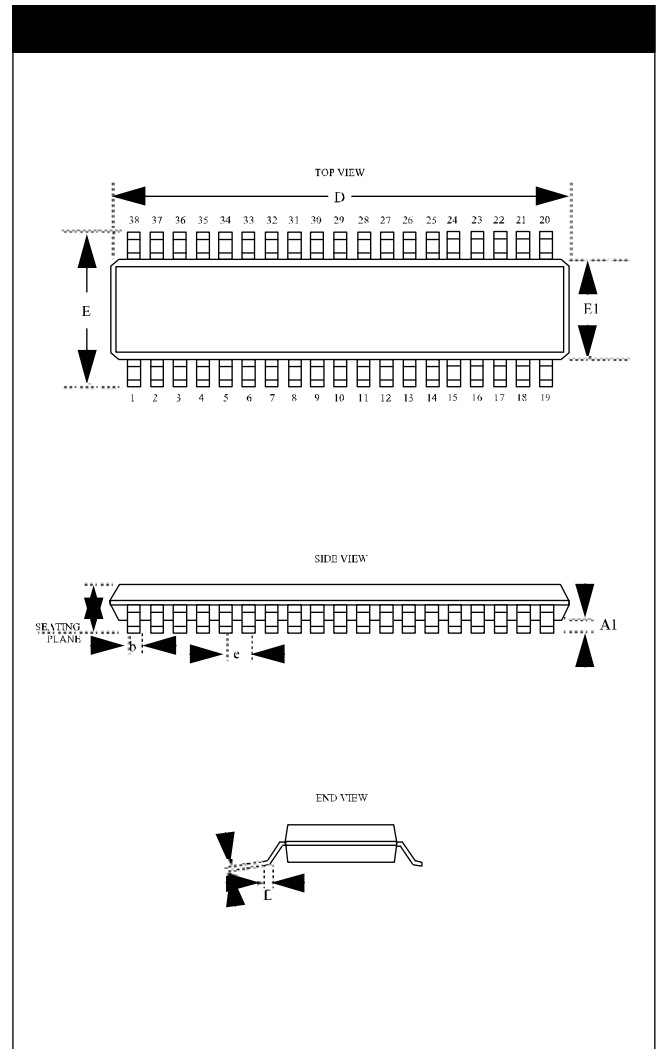

Package Dimensions for TSSOP-38

Tape and Reel Specifications

PART NUMBER	PACKAGE SIZE (mm)	POCKET SIZE (mm) $B_o \times A_o \times K_o$	TAPE WIDTH W	REEL DIAMETER	QTY PER REEL	P_o	P_1
CM2021-02TR	9.70 X 6.40 X 1.20	10.20 X 6.90 X 1.80	16mm	330mm (13")	2500	4mm	12mm

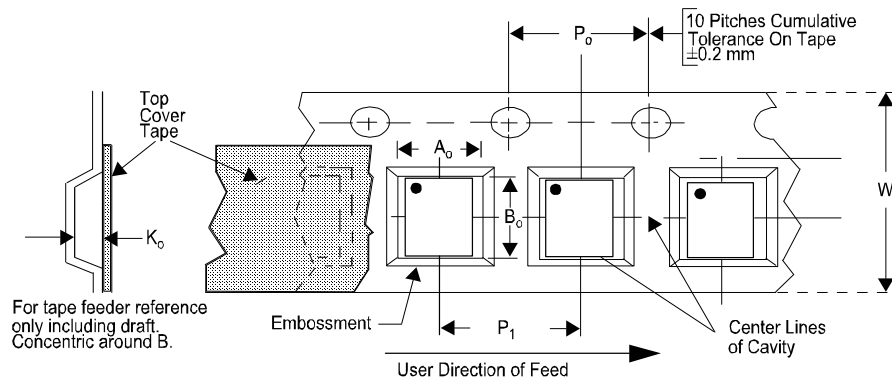

ON Semiconductor and  are registered trademarks of Semiconductor Components Industries, LLC (SCILLC). SCILLC reserves the right to make changes without further notice to any products herein. SCILLC makes no warranty, representation or guarantee regarding the suitability of its products for any particular purpose, nor does SCILLC assume any liability arising out of the application or use of any product or circuit, and specifically disclaims any and all liability, including without limitation special, consequential or incidental damages. "Typical" parameters which may be provided in SCILLC data sheets and/or specifications can and do vary in different applications and actual performance may vary over time. All operating parameters, including "Typicals" must be validated for each customer application by customer's technical experts. SCILLC does not convey any license under its patent rights nor the rights of others. SCILLC products are not designed, intended, or authorized for use as components in systems intended for surgical implant into the body, or other applications intended to support or sustain life, or for any other application in which the failure of the SCILLC product could create a situation where personal injury or death may occur. Should Buyer purchase or use SCILLC products for any such unintended or unauthorized application, Buyer shall indemnify and hold SCILLC and its officers, employees, subsidiaries, affiliates, and distributors harmless against all claims, costs, damages, and expenses, and reasonable attorney fees arising out of, directly or indirectly, any claim of personal injury or death associated with such unintended or unauthorized use, even if such claim alleges that SCILLC was negligent regarding the design or manufacture of the part. SCILLC is an Equal Opportunity/Affirmative Action Employer. This literature is subject to all applicable copyright laws and is not for resale in any manner.

PUBLICATION ORDERING INFORMATION

LITERATURE FULFILLMENT:
 Literature Distribution Center for ON Semiconductor
 P.O. Box 5163, Denver, Colorado 80217 USA
 Phone: 303-675-2175 or 800-344-3860 Toll Free USA/Canada
 Fax: 303-675-2176 or 800-344-3867 Toll Free USA/Canada
 Email: orderlit@onsemi.com

N. American Technical Support: 800-282-9855
 Toll Free USA/Canada
Europe, Middle East and Africa Technical Support:
 Phone: 421 33 790 2910
Japan Customer Focus Center
 Phone: 81-3-5773-3850

ON Semiconductor Website: www.onsemi.com

Order Literature: <http://www.onsemi.com/orderlit>

For additional information, please contact your local Sales Representative